

PRINTER SPECIFICATIONS

# ONYX PRO

The Onyx Pro features Markforged’s unique continuous fiber reinforcement at an affordable price. Built on a durable chassis with precision components, the Onyx Pro prints fiberglass reinforced thermoplastic parts that are 10x as strong as traditional printing plastics.

<b>PRINTER PROPERTIES</b>	<b>Process</b>	Continuous Fiber Reinforced Plastics
	<b>Build Volume</b>	320 x 132 x 154 mm (12.6 x 5.2 x 6 in)
	<b>Weight</b>	16 kg (35 lbs)
	<b>Machine Footprint</b>	584 x 330 x 355 mm (23 x 13 x 14 in)
	<b>Print Bed</b>	Flat to within 160 um - Kinematic coupling
	<b>Power</b>	100-240VAC, 150W (2A peak)
	<b>Mark Two Upgrade</b>	Carbon Fiber, HSHT, and Kevlar
<b>PART PROPERTIES</b>	<b>Layer Height</b>	100um default, 200um maximum
	<b>Ultimate Tensile Strength</b>	590 MPa (19.0x ABS, 16.4x Onyx)
	<b>Max Flexural Stiffness</b>	22 GPa (10.7x ABS, 7.6x Onyx)
	<b>Infill</b>	Closed Cell Infill: Multiple geometries available
<b>SOFTWARE</b>	<b>Supplied Software</b>	Markforged Software - Cloud Storage, Local Storage, or Fully On-Premise (\$5,000 added fee)
	<b>Security</b>	Two Factor Auth, Org Admin Access, Single Sign On
<b>MATERIALS</b>	<b>Plastics Available</b>	Onyx
	<b>Fibers Available</b>	Fiberglass

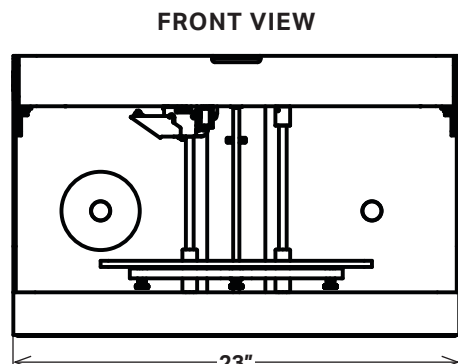
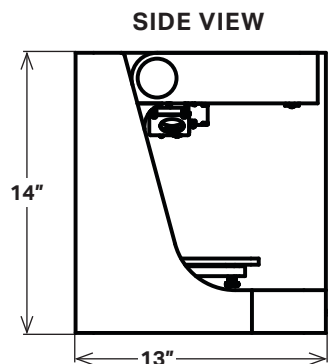

All specifications approximate and subject to change without notice.